

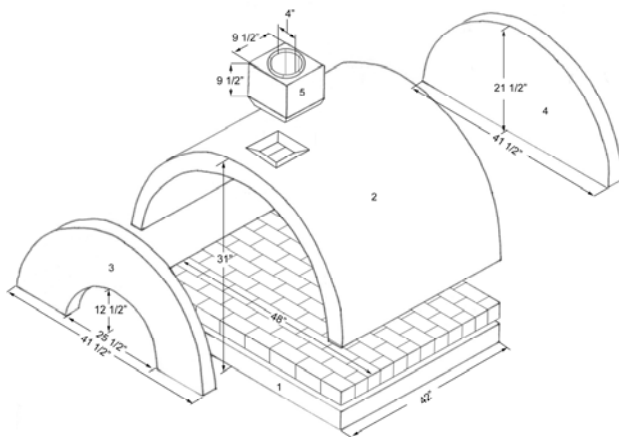

Amerigo™ Pizza Oven

Stone Age Manufacturing introduces the Amerigo™ Pizza Oven, featuring a one-piece arched-roof, for simplified construction and optimal cooking performance. The Amerigo™ offers a larger cooking surface, with over 1500 square inches of floor area, solid 3-inch thick walls for plenty of thermal mass, a wider door and more traditional styling than previous designs.



Stone Age Manufacturing, Inc.

11107 E. 126th St. North
Collinsville, OK 74021
www.stoneagefireplaces.com

Phone: (918) 371-8861
Fax: (918) 371-8850
E-mail: stoneagemfg@sbcglobal.net

Construction Diagram

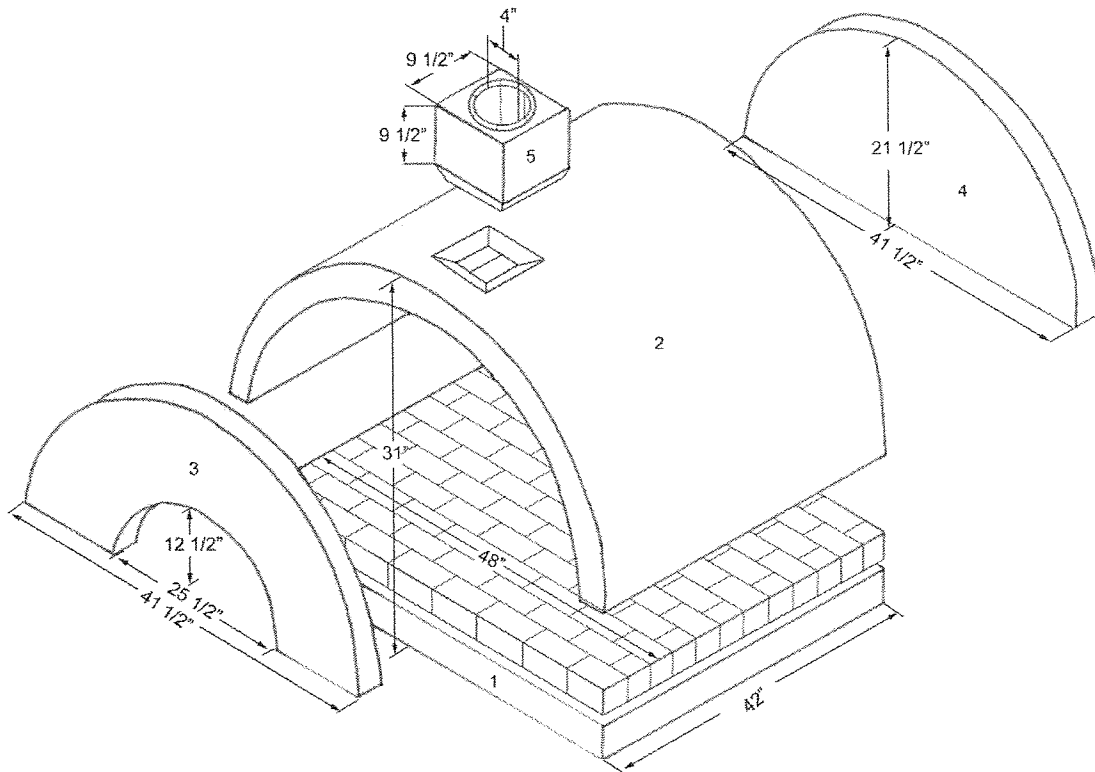

Steps for construction:

- 1) Determine the height you want the Oven Floor off Finished grade. Use Stone Age Cabinet Component System panels, optional Amerigo pizza oven wood box or concrete blocks to build base to desired height.
- 2) Once the base is level and square, set the base plate #1. Level it front to back and side to side. Use mortar with high-temperature additive for installation of firebrick and remaining pieces #2 - #5. Once level, install layer of firebrick on base plate, completely covering floor to edges.
- 3) Install pieces #2 - #5 in order shown in the picture. You are now ready for exterior finish.
- 4) Unit should not be fired for 21 days after completion, to allow full curing of mortar.

Dimensions: Outside - 42"d x 48"w x 31"t, Inside - 36"d x 41 1/2"w x 21 1/2"t
Door Opening - 25 1/2"w x 12 1/2"t

Weight: 1585 lbs. (approximate)

Note: Firebrick is required on floor of unit.